



**EQUALIZER™**  
INTERNATIONAL

FLANGE TOOL INNOVATION

# PRODUCT DATA SHEET

## SG13TE

### SECURE-GRIP HYDRAULIC FLANGE SPREADER

#### SPREADING FORCE:

With 700 bar (10 000 psi) of hydraulic pressure:  
13 T (130 kN) per tool

It is recommended that tools are used in pairs giving:  
2 x 13 T = 26 T (260 kN)

SPREADING DISTANCE: 0 mm - 115 mm (0" - 4.53")

TOOL WEIGHT: 21.5 kg (47.3 lb)

#### KIT COMPONENTS

- 1 x SG13TE Tool c/w Hydraulic Cylinder
- 1 x 700 bar (10 000 psi) HP 550S Sealed Hand Pump with Gauge
- 1 x 700 bar (10 000 psi) Hydraulic Hose, 2 m (78.7")
- 1 x 150 mm (6") Vernier Calliper
- 1 x (1/2") Square Drive Flexible Handle
- 1 x 30 mm (1 1/8") Drive Socket
- 1 x Safety Block
- 2 x M39 (1 1/2") Collets
- 2 x M42 (1 5/8") Collets
- 2 x M45 (1 3/4") Collets
- 1 x Instruction Manual
- 1 x Carry Case with protective foam inserts

Product Code: SG13TESTD



#### WEIGHTS AND DIMENSIONS

TOOL DIMENSIONS - CLOSED

TOOL DIMENSIONS - OPEN

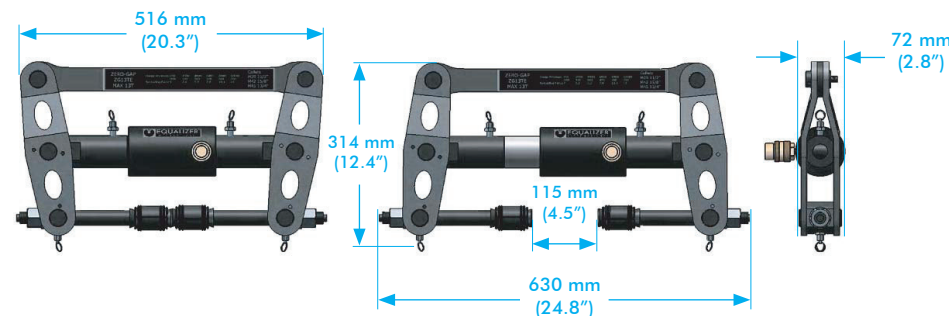

Tool Weight: 21.5 kg (47.3 lb)  
Case Weight: 9 kg (19.8 lb)  
Gross Kit Weight: 40.5 kg (89.3 lb)

Carry Case Dimensions:  
890 mm x 570 mm x 165 mm  
(35.0" x 22.4" x 6.5")

info@equalizerinternational.com  
www.equalizerinternational.com

# SG13TE

SECURE-GRIP HYDRAULIC FLANGE SPREADER



FLANGE TOOL INNOVATION

## RANGE OF APPLICATION

The SG13TE is usable on all standard flanges that have been specified to accept the following bolt sizes:  
M39 (1 1/2"), M42 (1 5/8"), M45 (1 3/4")

This includes ANSI, DIN, SPO, ASME, API and BS flanges.

For a detailed range of application please request the Secure-Grip Hydraulic Operator Instruction Manual.

## SPATIAL ENVELOPE

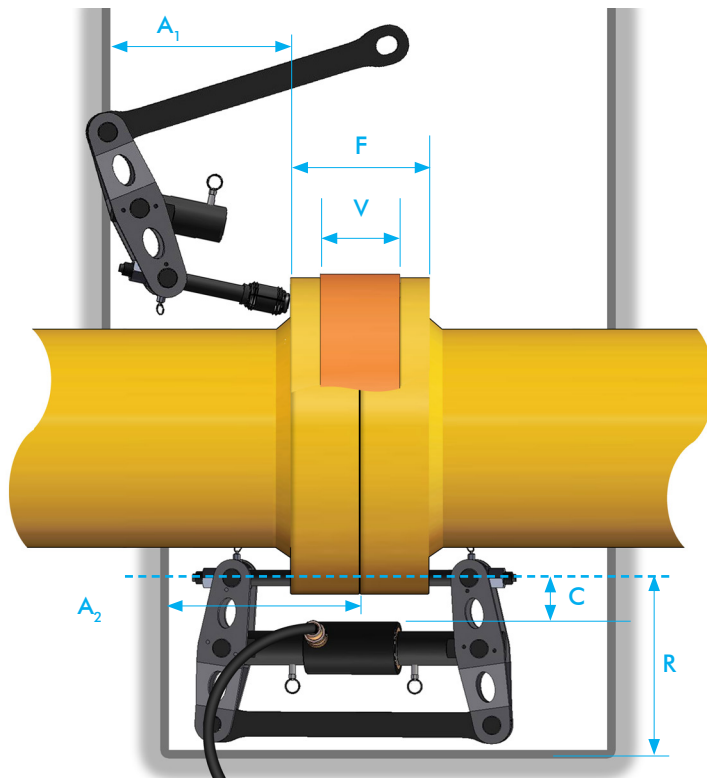

\*Short Collet Holder Kits (SCH) are available which can offer improved range of application.

\*\* Collet Holders can also be dismantled and inserted through bolt-holes from opposite side.

Contact Equalizer International if your application does not appear to suit standard tools.

	DIMENSION	MEASURED FROM	MEASURED TO	MINIMUM	MAXIMUM
F	Flange Joint Thickness	Outside Face of Flange	Outside Face of Flange	120 mm (4.7")	310 mm (12.2")
V	Valve/Spacer Thickness	Inside Face of Flange	Inside Face of Flange	*0.0 mm (0.0")	*95 mm (3.7")
C	Flange Clearance	Bolt-Hole Circle	Largest OD of Valve/Spacer	-	70 mm (2.8")
R	Radial space	Bolt-Hole Circle	Closest Obstruction	280 mm (11.0")	-
A <sub>1</sub>	Axial space (for installation)	Outside Face of Flange	Closest Obstruction	**310 mm (**12.2")	-
A <sub>2</sub>	Axial space (installed)	Inner Face of Flange	Closest Obstruction	260 mm (10.2")	-

Contact Equalizer International if your application does not appear to suit standard tools.