



EQUALIZERTM
INTERNATIONAL

FLANGE TOOL INNOVATION

PRODUCT DATA SHEET

SG15TE

SECURE-GRIP HYDRAULIC FLANGE SPREADER

SPREADING FORCE:

With 700 bar (10 000 psi) of hydraulic pressure:
15 T (150 kN) per tool

It is recommended that tools are used in pairs giving:
2 x 15 T = 30 T (300 kN)

SPREADING DISTANCE: 0 mm - 100 mm (0" - 3.94")

TOOL WEIGHT: 26 kg (57.3 lb)

KIT COMPONENTS

- 1 x SG15TE Tool c/w Hydraulic Cylinder
- 1 x 700 bar (10 000 psi) HP 550S Sealed Hand Pump with Gauge
- 1 x 700 bar (10 000 psi) Hydraulic Hose, 2 m (78.7")
- 1 x 300 mm (12") Vernier Calliper
- 1 x 1/2" Square drive flexible handle
- 1 x 36 mm (1/2") Drive Socket
- 1 x Safety Block
- 2 x M48 (1 7/8") Collets
- 2 x M52 (2") Collets
- 2 x M56 (2 1/4") Collets
- 1 x Instruction Manual
- 1 x Carry Case with protective foam inserts

Product Code: SG15TESTD



WEIGHTS AND DIMENSIONS

TOOL DIMENSIONS - CLOSED

TOOL DIMENSIONS - OPEN

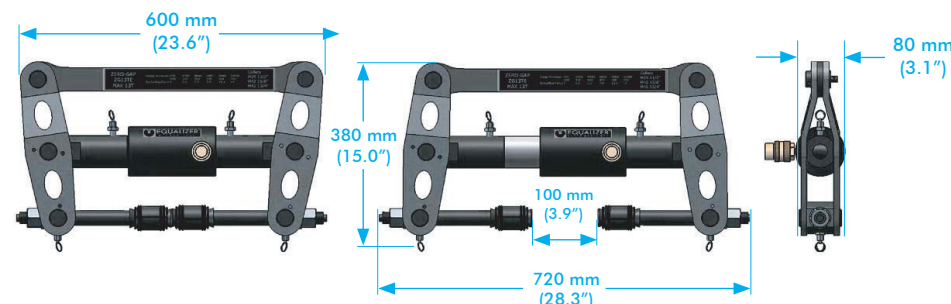

Tool Weight: 26 kg (57.3 lb)

Case Weight: 9 kg (19.8 lb)

Gross Kit Weight: 45 kg (99.2 lb)

Carry Case Dimensions:

890 mm x 570 mm x 165 mm
(35.0" x 22.4" x 6.5")

info@equalizerinternational.com
www.equalizerinternational.com

RANGE OF APPLICATION

The SG15TE is usable on all standard flanges that have been specified to accept the following bolt sizes:
M48 (1 7/8"), M52 (2"), M56 (2 1/4")

This includes ANSI, DIN, SPO, ASME, API and BS flanges.

For a detailed range of application please request the Secure-Grip Hydraulic Operator Instruction Manual.

SPATIAL ENVELOPE

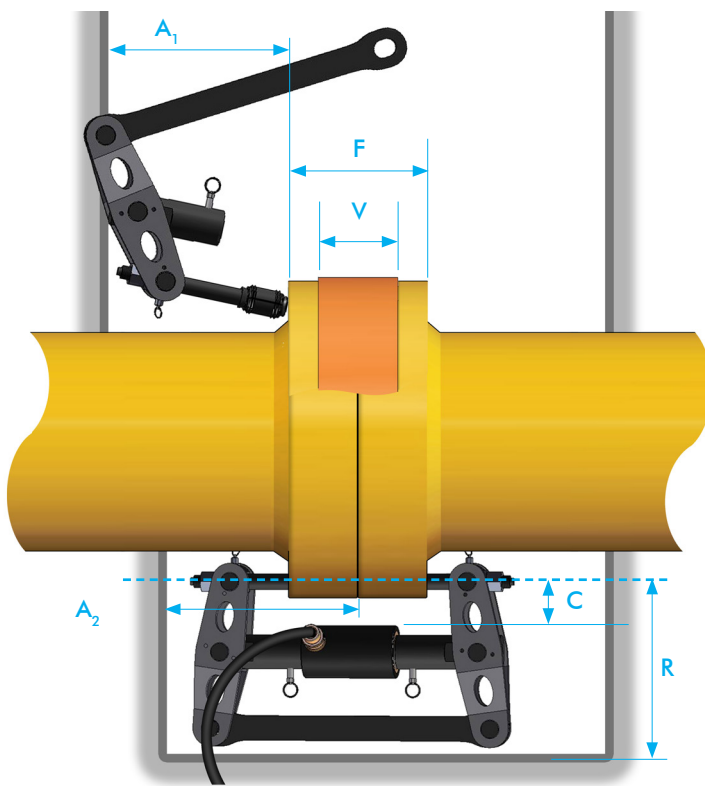

*Short Collet Holder Kits (SCH) are available which can offer improved range of application.

** Collet Holders can also be dismantled and inserted through bolt-holes from opposite side.

Contact Equalizer International if your application does not appear to suit standard tools.

	DIMENSION	MEASURED FROM	MEASURED TO	MINIMUM	MAXIMUM
F	Flange Joint Thickness	Outside Face of Flange	Outside Face of Flange	140 mm (5.5")	400 mm (15.7")
V	Valve/Spacer Thickness	Inside Face of Flange	Inside Face of Flange	*0.0 mm (0.0")	*80 mm (3.1")
C	Flange Clearance	Bolt-Hole Circle	Largest OD of Valve/Spacer	-	80 mm (3.1")
R	Radial space	Bolt-Hole Circle	Closest Obstruction	370 mm (14.6")	-
A ₁	Axial space (for installation)	Outside Face of Flange	Closest Obstruction	**380 mm (**15.0")	-
A ₂	Axial space (installed)	Inner Face of Flange	Closest Obstruction	315 mm (12.4")	-

Contact Equalizer International if your application does not appear to suit standard tools.