



**EQUALIZER™**  
INTERNATIONAL

FLANGE TOOL INNOVATION

# PRODUCT DATA SHEET

## SG18TE SECURE-GRIP IN-LINE HYDRAULIC FLANGE SPREADER

### SPREADING FORCE:

With 700 bar (10 000 psi) of hydraulic pressure:  
18 T (180 kN) per tool

It is recommended that tools are used in pairs giving:  
2 x 18 T = 36 T (360 kN)

SPREADING DISTANCE: 0 mm - 100 mm (0" - 3.9")  
TOOL WEIGHT: 14 kg (30.8 lb)

### KIT COMPONENTS

- 1 x SG18TE Tool c/w Hydraulic Cylinder
- 1 x Spreading plug
- 1 x 700 bar (10 000 psi) HP550S Sealed Hand Pump with Gauge
- 1 x 700 bar (10 000 psi) Hydraulic Hose, 2 m (78.7")
- 1 x 300 mm (12") Vernier Calliper
- 1 x 12.5 mm (0.5") Spacer Plate
- 1 x 5 mm Allen Key
- 1 x 50 mm (2.0") Spacer
- 1 x Safety Block
- 2 x M60 (2 3/8") Collets
- 2 x M64 (2 1/2") Collets
- 2 x M70 (2 3/4") Collets
- 1 x Instruction Manual
- 1 x Carry Case with protective foam inserts

Product Code: SG18TESTD



### WEIGHTS AND DIMENSIONS

Tool Weight: 14 kg (30.8 lb)  
Case Weight: 9 kg (19.8 lb)  
Gross Kit Weight: 45 kg (99.2 lb)

Carry Case Dimensions:  
890 mm x 570 mm x 165 mm (35.0" x 22.4" x 6.5")

TOOL DIMENSIONS - CLOSED

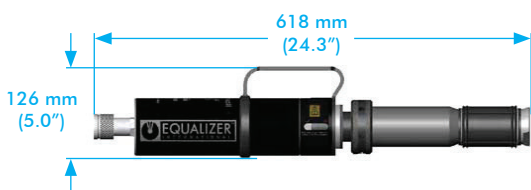

TOOL DIMENSIONS - OPEN



SPREADING PLUG DIMENSIONS

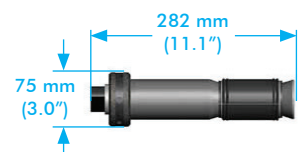

info@equalizerinternational.com  
www.equalizerinternational.com

## RANGE OF APPLICATION

The SG18TE is usable on all standard flanges that have been specified to accept the following bolt sizes:  
M60 (2 3/8"), M64 (2 1/2"), M70 (2 3/4")

This includes ANSI, DIN, SPO, ASME, API and BS flanges.

For a detailed range of application please request the Secure-Grip In Line Hydraulic Operator Instruction Manual.

## SPATIAL ENVELOPE

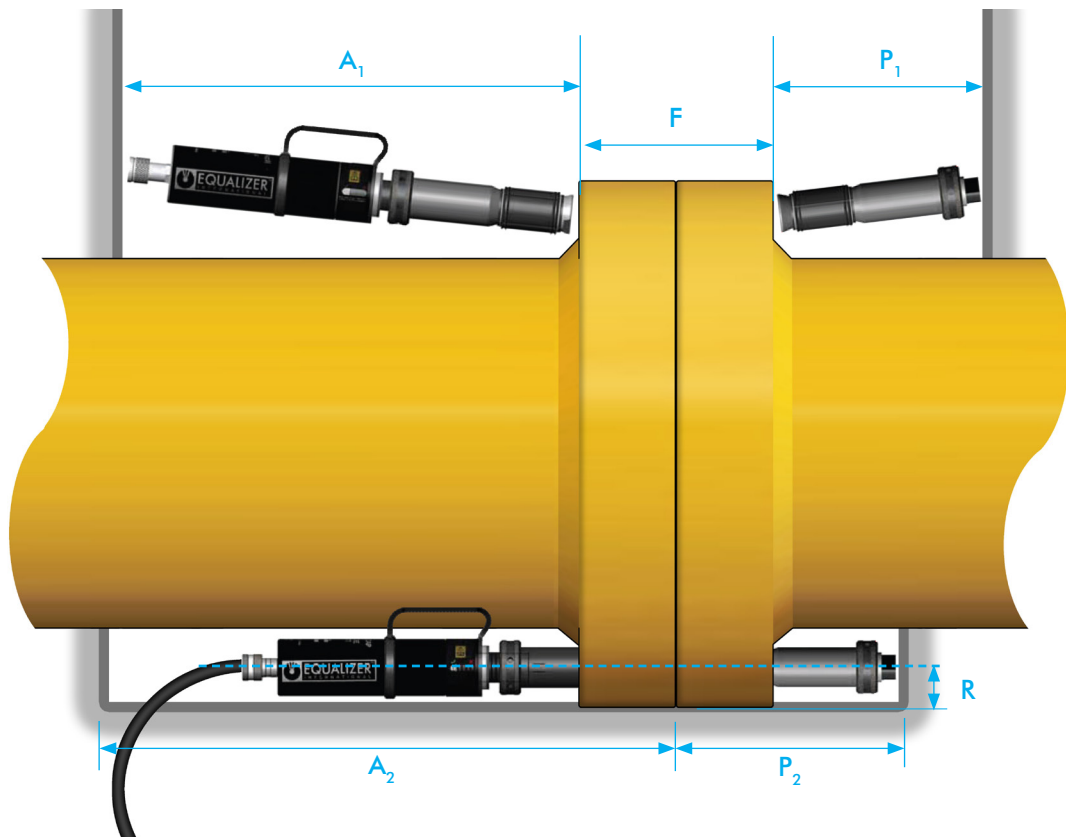

	DIMENSION	MEASURED FROM	MEASURED TO	MINIMUM	MAXIMUM
F	Flange Joint Thickness	Outside Face of Flange	Outside Face of Flange	190 mm (7.5")	450 mm (17.7")
R	Radial space	Bolt-Hole Circle	Closest Obstruction	55 mm (2.2")	-
A <sub>1</sub>	Axial Tool space (for installation)	Outside Face of Flange	Closest Obstruction	620 mm (24.4")	-
A <sub>2</sub>	Axial Tool space (installed)	Inner Face of Flange	Closest Obstruction	900 mm (35.4")	-
P <sub>1</sub>	Axial Plug space (for installation)	Outside Face of Flange	Closest Obstruction	283 mm (11.1")	-
P <sub>2</sub>	Axial Plug space (installed)	Inner Face of Flange	Closest Obstruction	283 mm (11.1")	-

Contact Equalizer International if your application does not appear to suit standard tools.