



"innovation in its most functional form"

## PRODUCT DATA SHEET



# SWi20/25TE

## HYDRAULIC FLANGE SPREADER

### SPREADING FORCE:

20T (200kN) 1st step

25T (240kN) 4th step

### SPREADING DISTANCE:

6.0 - 103.5mm (0.24 - 4.0")

WEIGHT: 6.4kg (14.02lb)

### CAPABILITIES

At 10,000psi – 700bar:

20T spread force (1st step)

24T spread force (4th step)

6.0mm – 87.5mm  
(0.24" - 3.4") spread over 4 steps  
(without stepped blocks)

48.5mm – 103.5mm  
(1.9" - 4.1") spread over 2 steps  
(with stepped blocks)

6.0mm – 40.0mm  
(0.24" - 1.6") spread  
using only 1st step



### TOOL DIMENSIONS - CLOSED

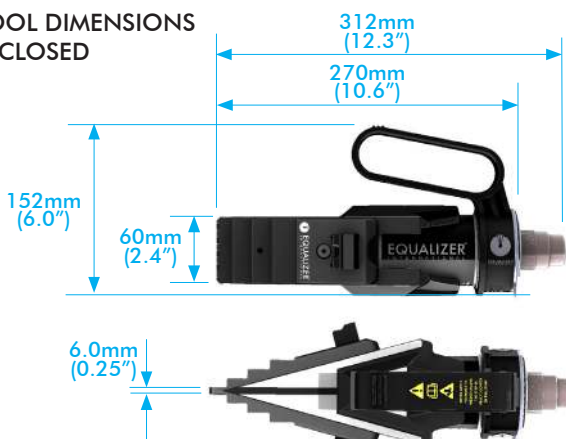

### USER FEATURES

- Practical, portable and lightweight
- Moulded plastic handle for comfort
- Revolving handle to aid horizontal or vertical spreading
- Offset handle is directly over the centre of mass
- Removable handle for improved access
- Revolving lanyard connection point
- Swivel hose coupler with elbow – improves access by allowing hose to revolve
- Spread indicator markings for clear precise visual progress feedback

### SAFETY FEATURES

- No finger pinch-points
- Increased step depth on upper steps
- Safety lanyard – 1.0m (39") length
- Partially recessed coupler reduces coupler vulnerability
- Forged key components for strength and reliability
- Fail-safe design – designated cylinder nose seal failure

### MAINTENANCE FEATURES

- Rapid disassembly and assembly
- Quick jaw replacement – remove 1 fastener
- Quick tip replacement – remove 2 fasteners
- Narrow jaw teeth – improved tool wear

info@equalizerinternational.com  
www.equalizerinternational.com

# SWi20/25TE

HYDRAULIC FLANGE SPREADER



"innovation in its most functional form"

## JAW DIMENSIONS (WITHOUT STEPPED BLOCKS ATTACHED)

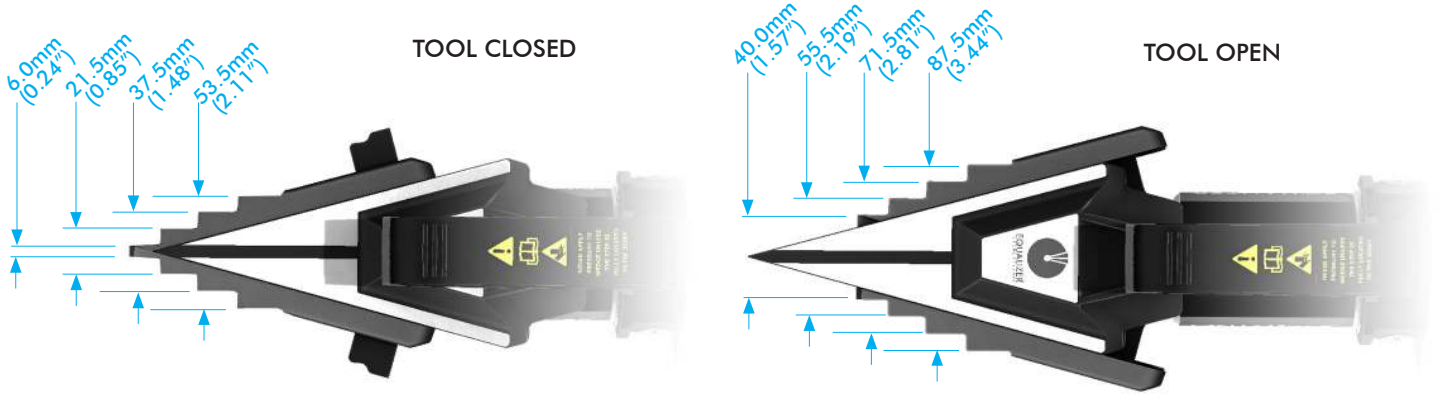

## JAW DIMENSIONS (WITH STEPPED BLOCKS ATTACHED)

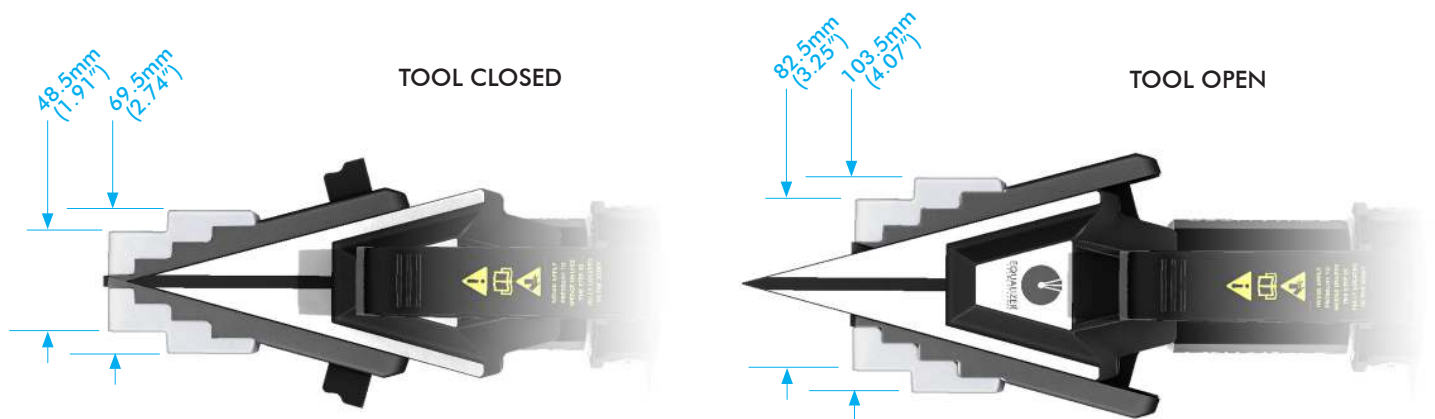

### MAXI KIT

- 2 x SWi20/25TE Flange Spreader Wedgeheads
- 2 x 10,000psi (700bar) Hydraulic Cylinders
- 2 x 10,000psi (700bar) Hydraulic Hoses, 2m (78.75") with 90 degree elbow
- 1 x 10,000psi (700bar) HP350D Sealed Hand Pump with Gauge
- 2 x Sets of Safety Blocks
- 2 x Pairs of Stepped Blocks
- 2 x Hex Keys
- 2 x Lanyard
- 1 x Instruction Manual
- 1 x Plastic Carry Case

920mm x 500mm x 205mm (36.2" x 19.7" x 8.1")  
Gross Kit Weight 32.4kg (71.5lb)  
Product Code: SWi2025TEMAXSPB



### STANDARD KIT

- 1 x SWi20/25TE Flange Spreader Wedgehead
- 1 x 10,000psi (700bar) Hydraulic Cylinder
- 1 x 10,000psi (700bar) Hydraulic Hose, 2m (78.75") with 90 degree elbow
- 1 x 10,000psi (700bar) HP350S Sealed Hand Pump with Gauge
- 1 x Set of Safety Blocks
- 1 x Pair of Stepped Blocks
- 1 x Hex Key
- 1 x Lanyard
- 1 x Instruction Manual
- 1 x Plastic Carry Case

920mm x 500mm x 205mm (36.2" x 19.7" x 8.1")  
Gross Kit Weight 20.7kg (45.7lb)  
Product Code: SWi2025TESTDSPB



### MINI KIT

- 1 x SWi20/25TE Flange Spreader Wedgehead
- 1 x 10,000psi (700bar) Hydraulic Cylinder
- 1 x Set of Safety Blocks
- 1 x Pairs of Stepped Blocks
- 1 x Hex Key
- 1 x Lanyard
- 1 x Instruction Manual
- 1 x Plastic Carry Case

580mm x 330mm x 165mm (22.8" x 13.0" x 6.5")  
Gross Kit Weight 11.6kg (25.6lb)  
Product Code: SWi2025TEMIN